



Year 3 Mid-year Reasoning

Name	
Class	
Date	

1. Write the missing numbers.

$$53 \xrightarrow{+10} \boxed{}$$

$$\boxed{} \xrightarrow{+10} 85$$

1 mark

2. Write these numbers in order, starting with the **smallest**.

841

184

148

814

144

<input type="text"/>	<input type="text"/>	<input type="text"/>	<input type="text"/>	<input type="text"/>
----------------------	----------------------	----------------------	----------------------	----------------------

1 mark

smallest

3. Write the missing fractions in the sequence.

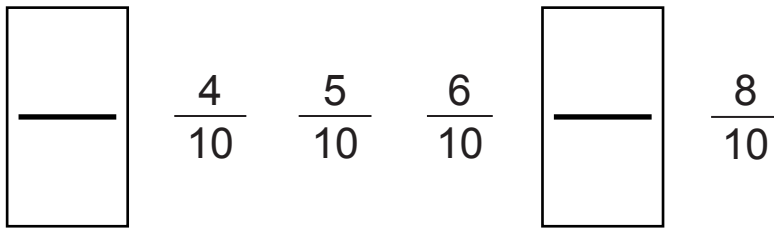

1 mark

4. Draw lines to join **all** the pairs of number cards which have a **difference of 40**

One has been done for you.

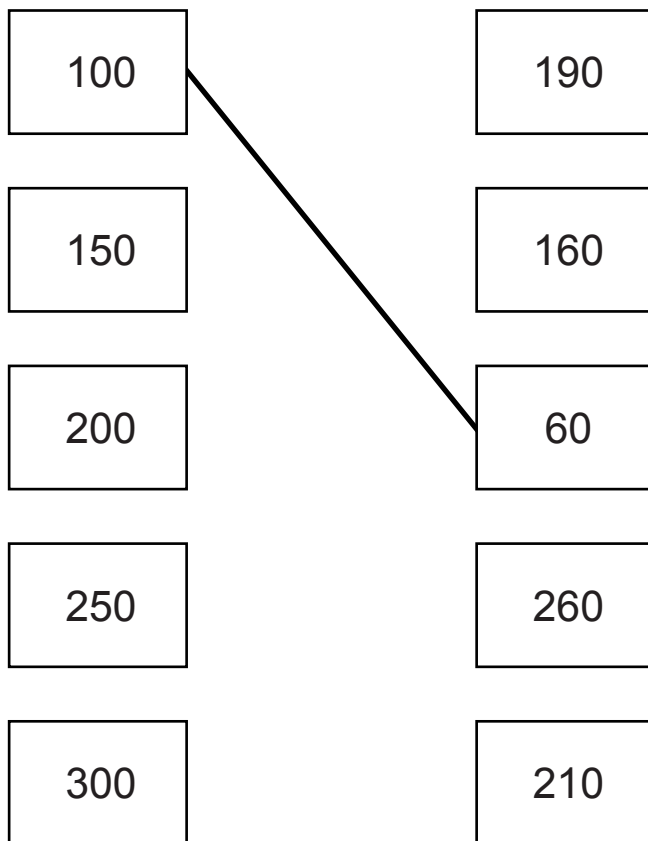

2 marks

5. Write the missing numbers.



1 mark

6. Join each box to the correct number.

One has been done for you.

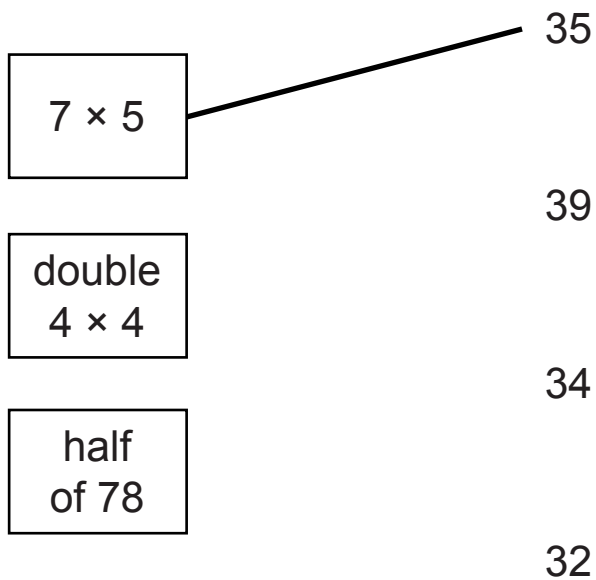

1 mark

7. Write the missing numbers.

$$690 = 600 + \boxed{}$$

$$702 = 700 + \boxed{}$$

1 mark

8. Jason has a jug with some water in.

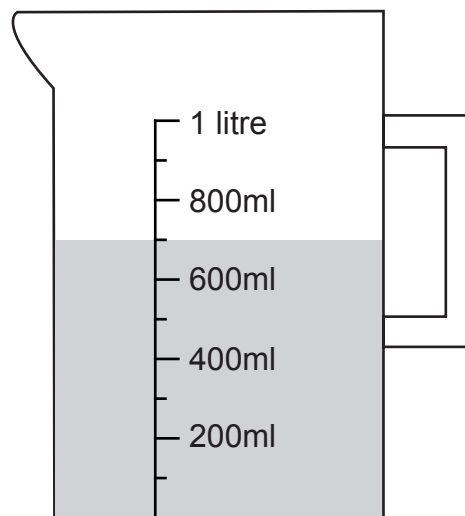

How many **more** millilitres must he add to make 1 litre?

ml

1 mark

9. Write in the missing digits.

$$\begin{array}{|c|} \hline 5 \\ \hline \end{array} \begin{array}{|c|} \hline \\ \hline \end{array} + \begin{array}{|c|} \hline \\ \hline \end{array} \begin{array}{|c|} \hline 3 \\ \hline \end{array} = \begin{array}{|c|} \hline 1 \\ \hline \end{array} \begin{array}{|c|} \hline 0 \\ \hline \end{array} \begin{array}{|c|} \hline 0 \\ \hline \end{array}$$

1 mark

10. Mia needs to solve this problem.

How many children in the class walk to school?

Tick (✓) **all** the information that Mia needs to solve her problem.

There are 18 boys in the class.

6 girls in the class walk to school.

Twice as many boys as girls walk to school.

1 mark

Jason needs to solve this problem.

How much do 3 bananas and a melon cost?

Tick (✓) **all** the information that Jason needs to solve his problem.

Jason has £3

A melon costs £1.50 more than a banana.

A banana costs 40p

1 mark

11. This graph shows the number of marbles that some children have.

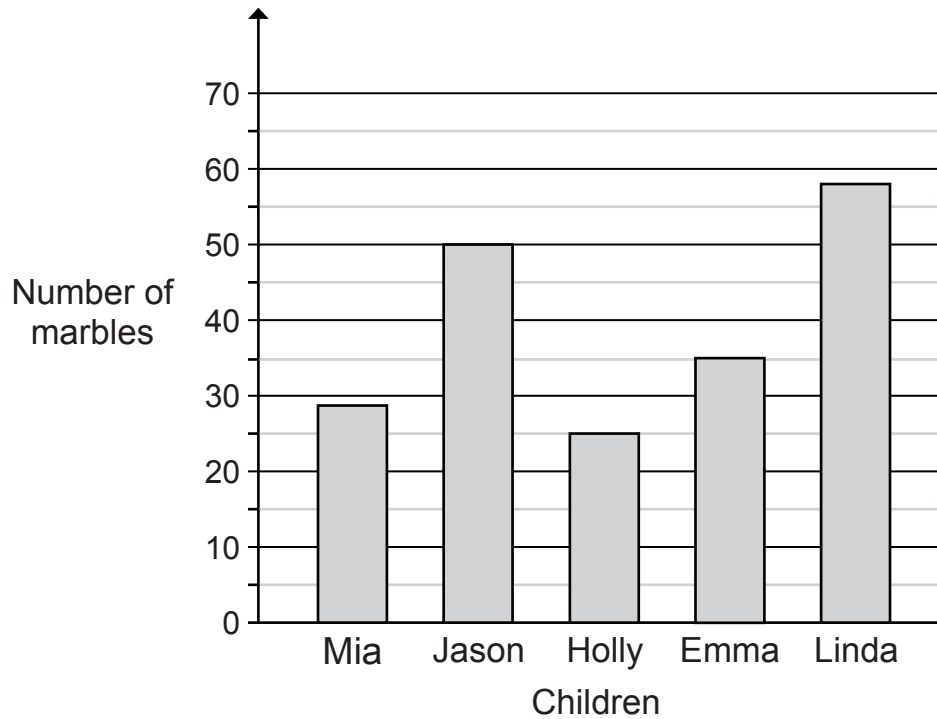

Who has between 30 and 40 marbles?

1 mark

Estimate how many marbles Mia has.

1 mark

12. Write the two missing numbers in this sequence.

$$\frac{1}{4} \quad \frac{1}{2} \quad \frac{3}{4} \quad 1 \quad \square \quad 1\frac{1}{2} \quad \square \quad 2$$

1 mark

13. Holly and Jason play a game.

Holly scores 80 points.

Jason scores 38 points.

How many **more** points does Holly score than Jason?

1 mark

14. Here is a multiplication.

$$3 \times 5 = 15$$

Write a **division** which uses the **same three numbers**.

1 mark

15. Here are some shapes on a square grid.

Tick (✓) the shape that has **exactly three** right angles.

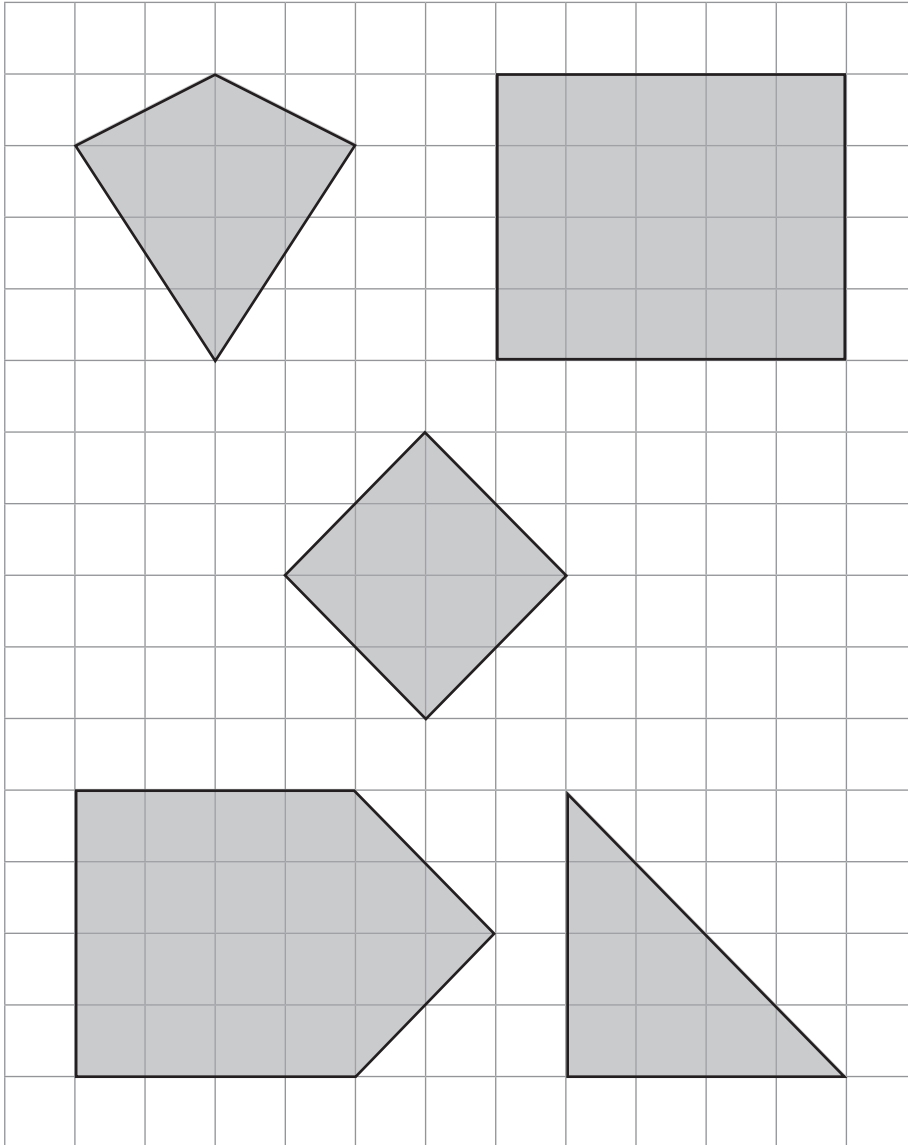

1 mark

16. Mia has these coins.



Holly has £1.50

How much **more** money does Mia have than Holly?

Show your method																														

£

2 marks

17. Here is a pizza cut into 8 equal slices.

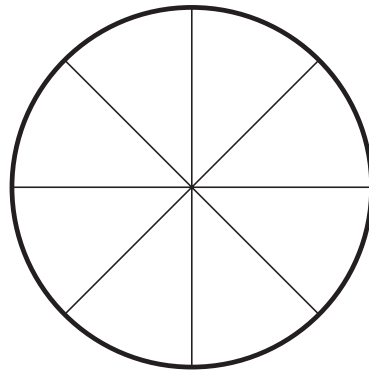

Jason eats 4 slices and Mia eats 1 slice.

What fraction of the pizza remains?

$\frac{\quad}{\quad}$

1 mark

18. Here is a shape divided into centimetre squares.

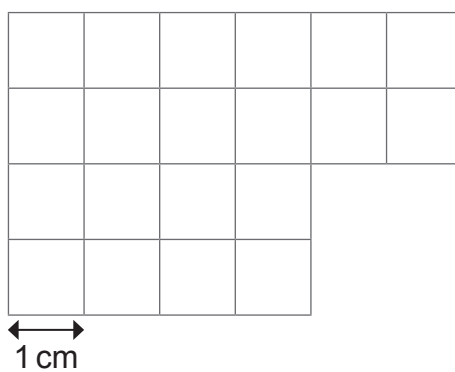

Actual size

What is the **perimeter** of the shape?

_____ cm

1 mark

19. Circle the **two** fractions that have the same value as $\frac{1}{2}$

$$\frac{2}{4} \quad \frac{2}{1} \quad \frac{3}{5} \quad \frac{5}{10} \quad \frac{1}{3}$$

1 mark

20. Jason gets **£5** pocket money each week.
Holly gets **£3** pocket money each week.
They both save all their money for **ten weeks**.

How much **more** money has Jason saved than Holly?

£

1 mark

21. Mia asked each child in her class,
'What kind of books do you prefer to read?'

Here are her results.

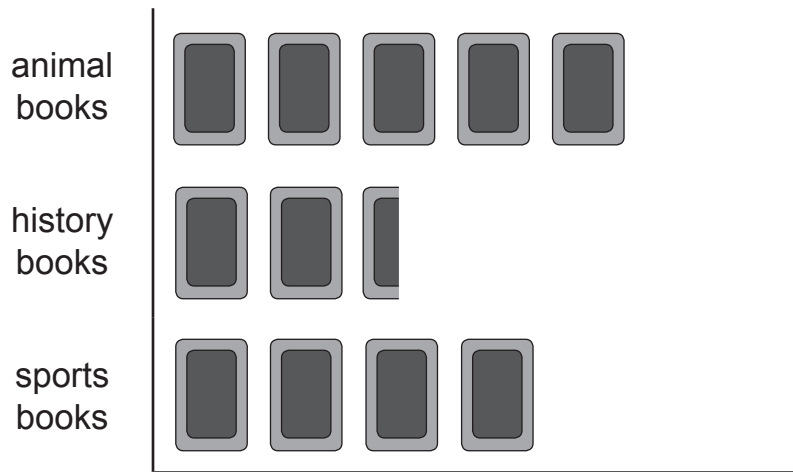
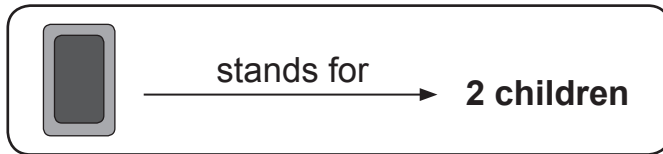

How many **more** children prefer to read animal books than history books?

1 mark

22. Here is a scale which shows the mass of an orange.

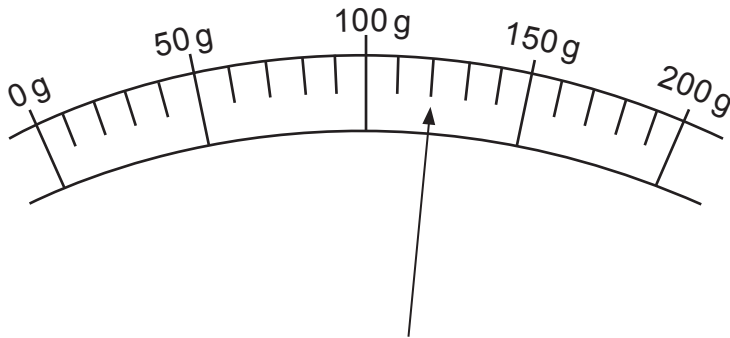

What is the mass of the orange?

grams

1 mark

23. In the high jump, Holly jumped 1 m 12 cm.
Jason jumped 95 cm.

How much higher was Holly's jump?

cm

1 mark

24. Mia wants to shade $\frac{3}{4}$ of this shape.
She has shaded 2 triangles.

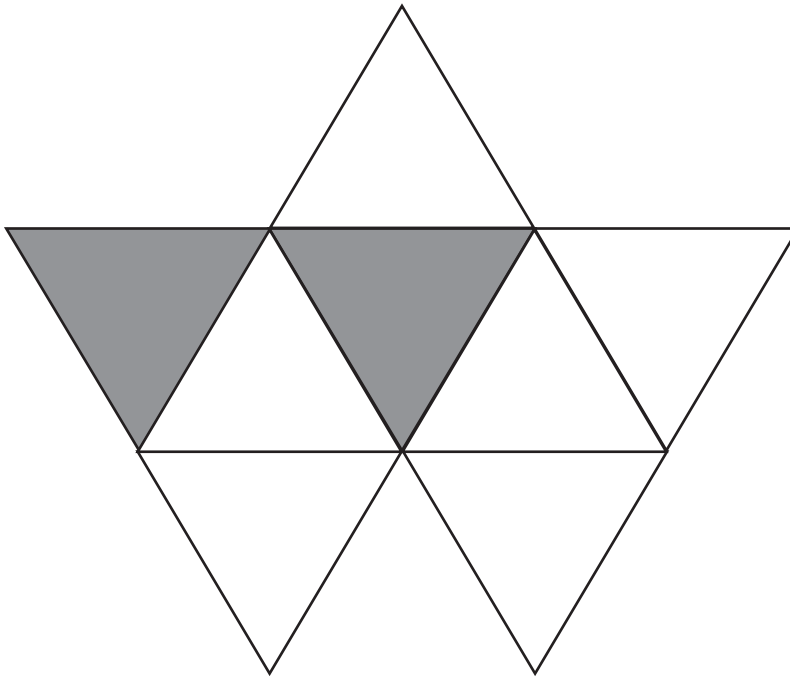

How many **more** triangles must she shade so that $\frac{3}{4}$ is shaded?

1 mark

25. Holly has four bowls.

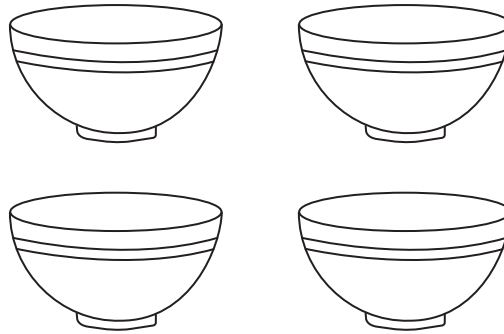

She puts 8 grapes in each bowl.

There are 5 grapes left over.

How many grapes did she start with?

grapes

1 mark

26. Here are four shapes.

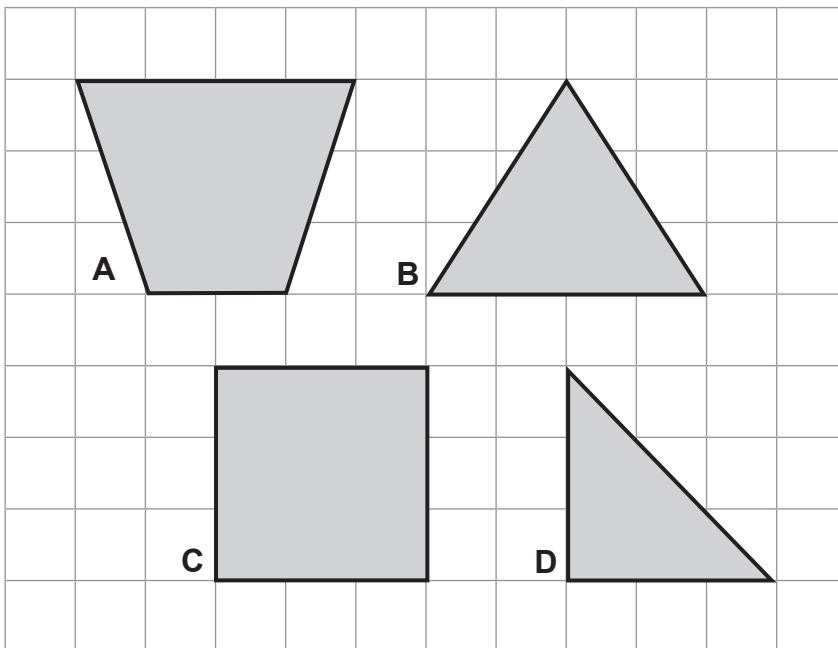

Write the letter of the shape that has **exactly** one pair of **perpendicular** sides.

1 mark

27. Here is part of a number line.

Write in the numbers missing from the two empty boxes.

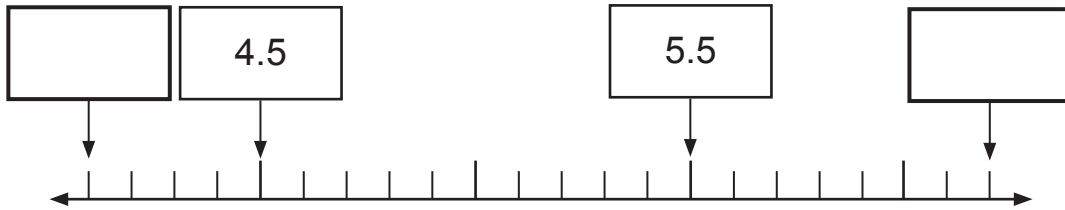

1 mark

1 mark

28. These clocks show the **start** and **finish** times of a film.

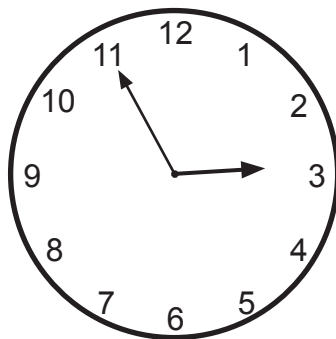

start

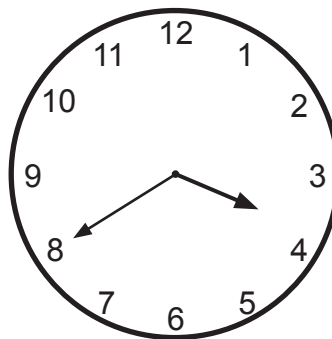

finish

How many minutes does the film last?

minutes

1 mark

29. Draw **two** lines to complete the square.

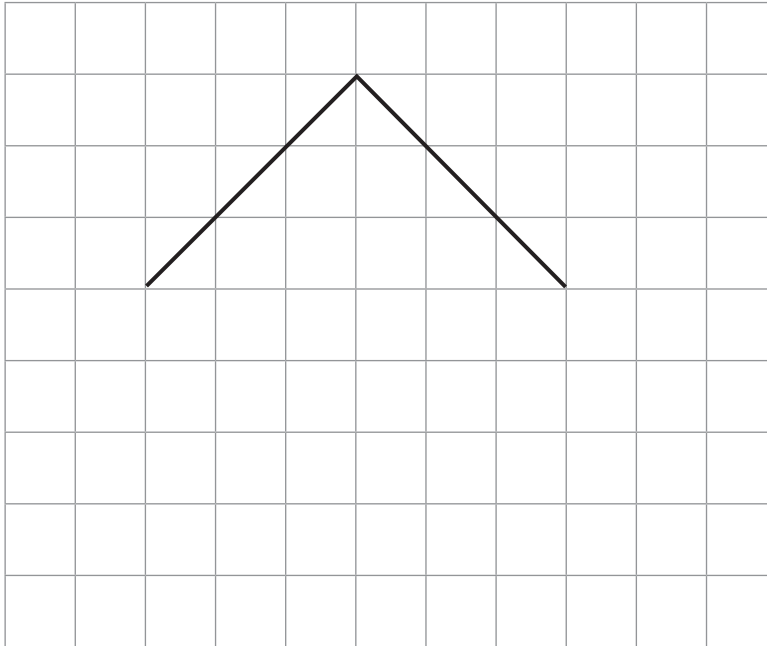

1 mark

30. Here are five digit cards.

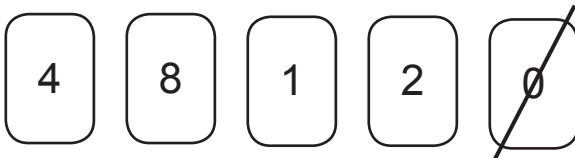

Three of these cards are used to make the number on the number line.

Write in the two missing digits.

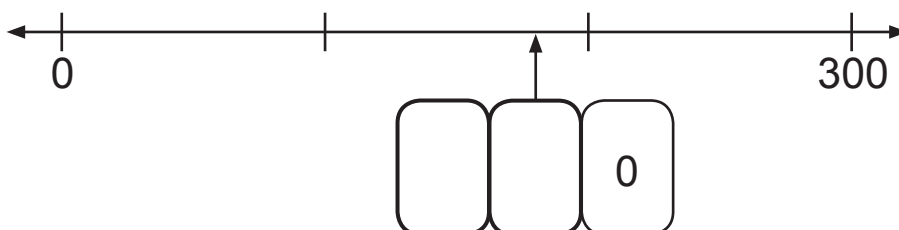

1 mark

